



UNIVERSITY OF CAMBRIDGE INTERNATIONAL EXAMINATIONS  
General Certificate of Education  
Advanced Subsidiary Level and Advanced Level

**MATHEMATICS**

**9709/41**

Paper 4 Mechanics 1 (M1)

**May/June 2010**

**1 hour 15 minutes**

Additional Materials:      Answer Booklet/Paper  
   Graph Paper  
   List of Formulae (MF9)



**READ THESE INSTRUCTIONS FIRST**

If you have been given an Answer Booklet, follow the instructions on the front cover of the Booklet.

Write your Centre number, candidate number and name on all the work you hand in.

Write in dark blue or black pen.

You may use a soft pencil for any diagrams or graphs.

Do not use staples, paper clips, highlighters, glue or correction fluid.

Answer **all** the questions.

Give non-exact numerical answers correct to 3 significant figures, or 1 decimal place in the case of angles in degrees, unless a different level of accuracy is specified in the question.

Where a numerical value for the acceleration due to gravity is needed, use  $10 \text{ m s}^{-2}$ .

The use of an electronic calculator is expected, where appropriate.

You are reminded of the need for clear presentation in your answers.

At the end of the examination, fasten all your work securely together.

The number of marks is given in brackets [ ] at the end of each question or part question.

The total number of marks for this paper is 50.

Questions carrying smaller numbers of marks are printed earlier in the paper, and questions carrying larger numbers of marks later in the paper.

This document consists of 4 printed pages.



- 1 A car of mass 1150 kg travels up a straight hill inclined at  $1.2^\circ$  to the horizontal. The resistance to motion of the car is 975 N. Find the acceleration of the car at an instant when it is moving with speed  $16 \text{ m s}^{-1}$  and the engine is working at a power of 35 kW. [4]

2

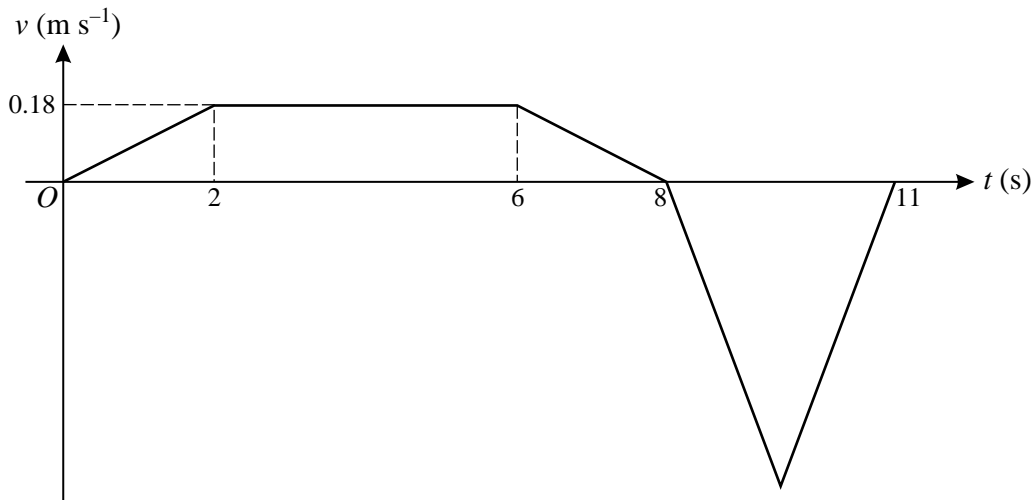

The diagram shows the velocity-time graph for the motion of a machine's cutting tool. The graph consists of five straight line segments. The tool moves forward for 8 s while cutting and then takes 3 s to return to its starting position. Find

- (i) the acceleration of the tool during the first 2 s of the motion, [1]  
 (ii) the distance the tool moves forward while cutting, [2]  
 (iii) the greatest speed of the tool during the return to its starting position. [2]

3

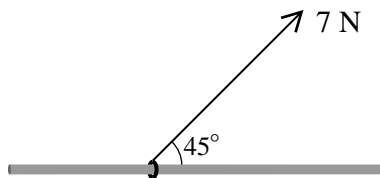

A small ring of mass 0.8 kg is threaded on a rough rod which is fixed horizontally. The ring is in equilibrium, acted on by a force of magnitude 7 N pulling upwards at  $45^\circ$  to the horizontal (see diagram).

- (i) Show that the normal component of the contact force acting on the ring has magnitude 3.05 N, correct to 3 significant figures. [2]  
 (ii) The ring is in limiting equilibrium. Find the coefficient of friction between the ring and the rod. [3]

4

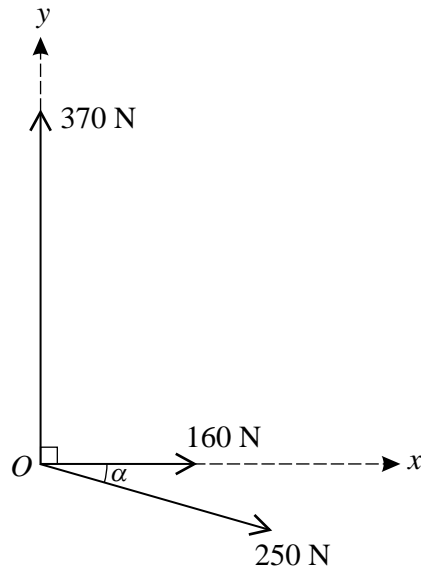

Coplanar forces of magnitudes 250 N, 160 N and 370 N act at a point  $O$  in the directions shown in the diagram, where the angle  $\alpha$  is such that  $\sin \alpha = 0.28$  and  $\cos \alpha = 0.96$ . Calculate the magnitude of the resultant of the three forces. Calculate also the angle that the resultant makes with the  $x$ -direction.

[7]

5  $P$  and  $Q$  are fixed points on a line of greatest slope of an inclined plane. The point  $Q$  is at a height of 0.45 m above the level of  $P$ . A particle of mass 0.3 kg moves upwards along the line  $PQ$ .

(i) Given that the plane is smooth and that the particle just reaches  $Q$ , find the speed with which it passes through  $P$ . [3]

(ii) It is given instead that the plane is rough. The particle passes through  $P$  with the same speed as that found in part (i), and just reaches a point  $R$  which is between  $P$  and  $Q$ . The work done against the frictional force in moving from  $P$  to  $R$  is 0.39 J. Find the potential energy gained by the particle in moving from  $P$  to  $R$  and hence find the height of  $R$  above the level of  $P$ . [4]

[Questions 6 and 7 are printed on the next page.]

6

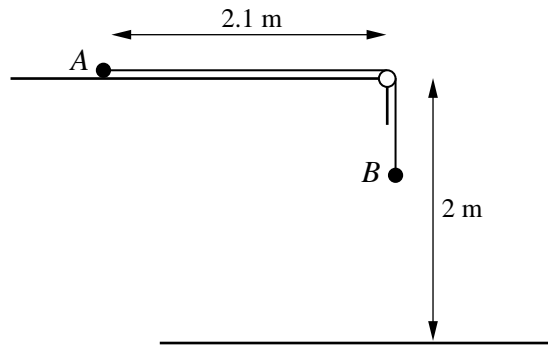

Particles  $A$  and  $B$ , of masses  $0.2\text{ kg}$  and  $0.45\text{ kg}$  respectively, are connected by a light inextensible string of length  $2.8\text{ m}$ . The string passes over a small smooth pulley at the edge of a rough horizontal surface, which is  $2\text{ m}$  above the floor. Particle  $A$  is held in contact with the surface at a distance of  $2.1\text{ m}$  from the pulley and particle  $B$  hangs freely (see diagram). The coefficient of friction between  $A$  and the surface is  $0.3$ . Particle  $A$  is released and the system begins to move.

- (i) Find the acceleration of the particles and show that the speed of  $B$  immediately before it hits the floor is  $3.95\text{ m s}^{-1}$ , correct to 3 significant figures. [7]
- (ii) Given that  $B$  remains on the floor, find the speed with which  $A$  reaches the pulley. [4]

7 A vehicle is moving in a straight line. The velocity  $v\text{ m s}^{-1}$  at time  $t\text{ s}$  after the vehicle starts is given by

$$v = A(t - 0.05t^2) \quad \text{for } 0 \leq t \leq 15,$$

$$v = \frac{B}{t^2} \quad \text{for } t \geq 15,$$

where  $A$  and  $B$  are constants. The distance travelled by the vehicle between  $t = 0$  and  $t = 15$  is  $225\text{ m}$ .

- (i) Find the value of  $A$  and show that  $B = 3375$ . [5]
- (ii) Find an expression in terms of  $t$  for the total distance travelled by the vehicle when  $t \geq 15$ . [3]
- (iii) Find the speed of the vehicle when it has travelled a total distance of  $315\text{ m}$ . [3]

Permission to reproduce items where third-party owned material protected by copyright is included has been sought and cleared where possible. Every reasonable effort has been made by the publisher (UCLES) to trace copyright holders, but if any items requiring clearance have unwittingly been included, the publisher will be pleased to make amends at the earliest possible opportunity.

University of Cambridge International Examinations is part of the Cambridge Assessment Group. Cambridge Assessment is the brand name of University of Cambridge Local Examinations Syndicate (UCLES), which is itself a department of the University of Cambridge.